

Available online at: <https://ijact.in>

Date of Submission	19/06/2020
Date of Acceptance	20/07/2020
Date of Publication	01/08/2020
Page numbers	3775-3783 (9 Pages)

This work is licensed under Creative Commons Attribution 4.0 International License.



ISSN:2320-0790

A REVIEW ON RECENT ADVANCES IN DEEP LEARNING FOR SENTIMENT ANALYSIS: PERFORMANCES, CHALLENGES AND LIMITATIONS

Md Shofiqul Islam^{1,2}, Ngahzaifa Ab Ghani^{1,2*}, Md Manjur Ahmed³

¹Faculty of Computing, Universiti Malaysia Pahang, 26300 Kuantan, Pahang, Malaysia

²IBM Centre of Excellence (Universiti Malaysia Pahang), Cybercentre, Pahang Technology Park, 26300 Kuantan, Pahang, Malaysia

³Faculty of Computer Science and Engineering, University of Barisal, Barisal 8200, Bangladesh.
shafiqcseiu07@gmail.com, zaifa@ump.edu.my, manjur_39@yahoo.com

Abstract: Now days the horizons of social online media keep expanding, the impacts they have on people are huge. For example, many businesses are taking advantage of the input from social media to advertise to specific target market. This is done by detecting and analyzing the sentiment (emotions, feelings, opinions) in social media about any topic or product from the texts. There are numerous machine learning as well as natural language processing methods used to examine public opinions with low time complexity. Deep learning techniques, however, have become widely popular in recent times because of their high efficiency and accuracy. This paper provides a complete overview of the common deep learning frameworks used in sentiment analysis in recent time. We offer a taxonomical study of text representations, learning model, evaluation, metrics and implications of recent advances in deep learning architectures. We also added a special emphasis on deep learning methods; the key findings and limitations of different authors are discussed. This will hopefully help other researchers to do further development of deep learning methods in text processing especially for sentiment analysis. The research also presents the quick summaries of the most popular datasets, lexicons with their related research, performance and main features of the datasets. The aim of this survey is to emphasize the ability to solve text-based sentiment analysis challenges in deep learning architectures with successful achievement for accuracy, speed with context, syntactic and semantic meaning. This review paper analyzes uniquely with the progress and recent advances in sentiment analysis based on existing advanced methods and approach based on deep learning with their findings, performance comparisons and the limitations.

Keywords: Sentiment Analysis(SA); Text; Deep learning; Emotion Recognition (ER); Classifiers; Neural Network (NN).

I. INTRODUCTION

Social media is leading a great role in content sharing. People express their feelings towards any particular topics in social media in order to alert other users, gain attention, spread information, or mostly just sharing their opinions whether it is positive or negative. This is why users' opinions are very useful in predicting the interest of users on any particular topics of interest. As useful as it is, it is also nearly impossible to manually and systematically

analyze opinions in social media from thousands of comments. This is where data mining and machine learning come into the picture. Sentiment analysis is a part of data mining that analyzes the text using the natural language processing and also the computational linguistics to extract the people's opinions & feelings from subjective information obtained from online platforms like social media, shopping websites or applications. It also analyzes in-depth to the strength of the feelings, from parameters known as sentiment score. There is a close connection

between emotions recognition and opinion mining. It also covers machine linguistics, text mining and the storage of natural languages. It can help society to explore an individual in psychology through researching feelings, but it involves word abstraction. [1]. Sentiment analysis is done based on the reviews or comments from humans on social media or other sources. Nevertheless, feeling research are sometimes difficult because text can be tactical. The sentiment analysis has categorized mainly into three levels [2], which are document level, sentence level and the last one is aspect levels. Sentiment analysis in document-level is the simplest way to analyze public sentiments. It finds overall polarity and cannot find individual emotion for different entity. It aims to categorize the entire opinion document into one object unit, such as a book, business or hotel [1] where the whole file is used to assess whether it is positive or negative. On the other hand, Sentence-level sentiment analysis handles sentiment at sentence level with better performance for subjectivity and objectivity but it is not suitable for complex sentence [3]. The last type of sentiment analysis is aspect level sentiment analysis that is able to handle negation for simple and short sentence but weak in performance for negation in long and complex [3]. Aspect does not consider the language structure such as articles, sentences and clauses as compared to the other two levels. It helps to determine a sentence by separating feelings (negative or positive) as well as its objective (object).

A. Applications of sentiment analysis with the model of deep learning

There are a lot of existing research and applications on sentiment analysis. In most cases, sentiment analysis is used for review analysis on social media data, financial market prediction, event prediction etc. Table shown gives the recent application of sentiment analysis in different fields.

Name of Applications of Sentiment analysis	Authors and Years
Social media opinion analysis	[4] -2020,[5] -2019
Emotion Analysis	[6]-2020,[7] -2019,[8] -2018
Road Traffic Congestion	[9]-2020
Event prediction	[10]-2018
Disaster Prediction and analysis	[11]-2020,[12]-2018
Product Review Analysis	[13] -2020,[14] -2019
Movie Review	[15]-2019
Restaurant Review	[16] -2020
Stock Market prediction	[17] -2018
Politics	[18]-2018,[19]-2017

Table-1: Application of Sentiment Analysis.

B. Sentiment analysis architecture with model of deep learning

In sentiment analysis there are some basic steps. This section deals with the description of the basic architecture for sentiment analysis with model of deep learning as shown in Figure-1.

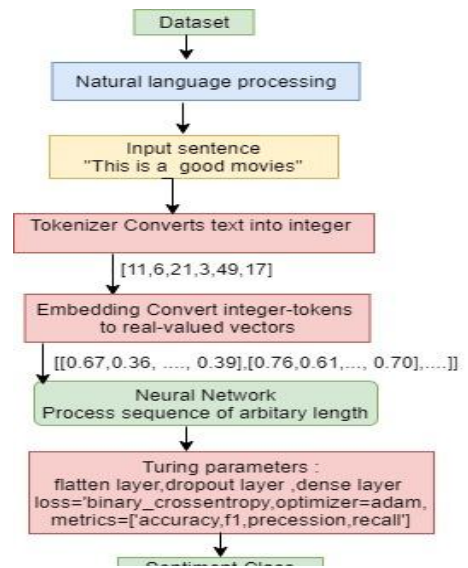

Figure-1: Deep learning architecture for SA

The first step is data collection then followed by data pre-processing using NLP tools then tokenization of each word to convert into integer. The tokenized integers will be converted into real valued vector before forwarded to deep learning framework where tuning of different parameters to predict the sentiment class is done.

C. Text Embedding

The inputs cannot be taken directly from the deep learning framework, which is why data must be embedded. Several embedding strategies are possible. The embedding layer includes a vector representation based on the semantic connection to the relevant word with each incoming text word. Tabel-2 shows the developer and the related research, with some common text encoding briefly discussed.

Used Text Embedding with author	Features of text embedding	One related Reference and Year	Details of using embedding and Deep learning model on related research
Word2vec [20]	It used the distributed representation of each words	[21]-2019	Uses Semanitic and emotion embedding for BiLSTM and CNN model
Bag of words[22]	Words(multiset) of a text is represented as bag of words (BOW)	[21]-2016	Denosing auto encoder model uses target-oriented features of BOW with loss.
Concatenated embeddings with SSWE and word2vec	SSWE provided a very strict learning by the analysis of the positive and also negative n-gram	[23]-2016	Uses Bidirectional and tri-way gated neural network with target oriented interaction of entity

Word embeddings with pre-trained word2vec and the Skip-gram	It used the distributed representation of each words and in SG skipping word with length 1.	[24]-2018	Uses attention based hierarchical model of LSTM with incorporating common sense knowledge of all sentiment concepts
FastText[20]	The word representation is taught effectively when utilizing the details at the character level then this tools fastText is also works for all of the rear words	[25]-2018	CNN model uses this domain-specific double embedding mechanism
GloVe[26]	Glove vectors is unsupervised, and the terms are represented by the vector for each words. The terms are identified by word similarity distance as well as semantic space	[16]-2020	MAN model uses two level embedding GloVec(Local and word level interaction)
BERT[27]	BERT pretrains dual-directional representations of unlabelled data in each of these layers	(Gao, Feng, Song, & Wu, 2019)	BERT used for target dependent sentiment classification.

Table-2: Summary of text embedding in deep learning based SA.

D. Deep Learning Model

There are three basic steps in the deep learning-based model which are application, architecture and preparation of inputted text using different embedding approach then feed forwarded to the deep learning model named CNN, RNN based model and finally predict NLP application. This section gives overall information about the tools and methods used in deep learning. Figure-2 shows the overall deep learning model for sentiment analysis.

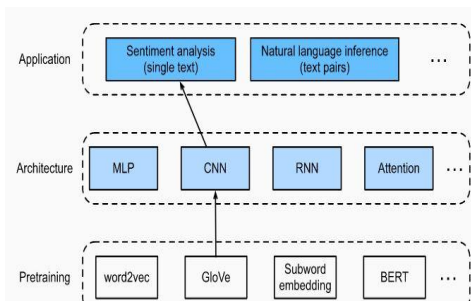

Figure-2: Deep learning based model for sentiment analysis

E. Convolutional Neural Network:

A convolution layer learns to convert small data parts into high-level characteristic vectors. In 2014, Kim has developed and applied CNN [28]. Figure-3 shows basic

structure of a CNN model with its related layers. Convolutional neural networks (CNNs) are generally flexible with larger inputs and very broad scale. Unlike conventional ANNs, CNNs include inputs, completely connected as well as output layers, but they do have convolutional and pooling layers including additional layers which are essential to CNN effectiveness. Such layers involve the processing of filtered feature maps. A feature map is source data representations. In back propagation time, the filters used in both convolution and pooling layers.

Figure-3 shows the basic structure of CNN model.

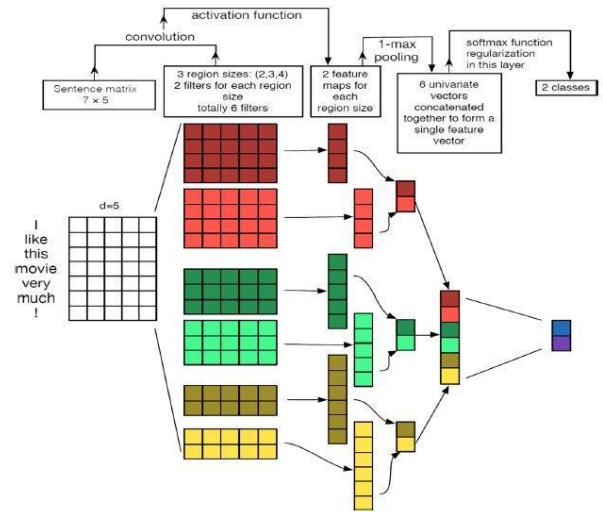

Figure-3: CNN model [29].

F. Long Term Short Term Memory(LSTM)

LSTM is generally an RNN prolongation that requires inputs to be stored for a long period. LSTM has an advanced memory, as opposed to RNN's basic internal memories. Figure-4 shows basic architecture of LSTM. The memory content can be read, written and erased. Therefore, it addresses RNN's drawback that suffered from vanishing point. LSTM will determine which knowledge to remember and what to forget. The memory may be gated in LSTM. It has three gates named as input, forget and the output gates. Basic equation of LSTM is given below.

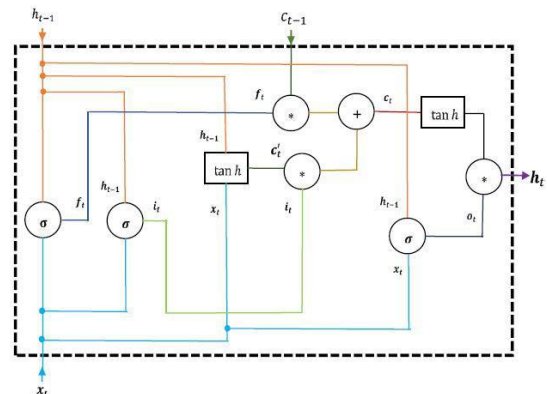

Figure-4: LSTM memory cell [30]

$$i_t = \sigma(w_i[h_{t-1}, x_t] + b_i), f_t = \sigma(w_f[h_{t-1}, x_t] + b_f), o_t = \sigma(w_o[h_{t-1}, x_t] + b_o)$$

Here, i_t is used for input gate, o_t for output gate and f_t denotes forget gate. σ represents the activation function, w_x is used to indicate weights of different gates(x), h_{t-1} is the output from the previous LSTM with time stamp t-1, x_t is the current time stamp, b used for bias value in different gates.

G. Attention mechanism with RNN

Attention processes have become popular in the NLP with a significant paper regarding machine translation[31]. RNN works with a single hidden layer in order to obtain an intuition for the attention process. The goal of the network for the attention function is to extract the meaning of each hidden state and to calculate the value of a weighted summation of features. Here Figure-5 is the schematic from Bahdanau's Attention Method. An LSTM series for each input sentence is generated throughout the Bidirectional LSTM used in this (h1. h2. hTx). All the h1,h2 ..., etc. vectors used during their function simply are just the concatenation with hidden states as forward and backwards in the encoder. In basic terms, the Tx indicates words number in the input sentence is represented by the vectors variables h1,h2,h3, hTx. Only the last condition of the encoder, LSTM (hTx in this case), works as context vector on the basic encoder as well as decoder method.

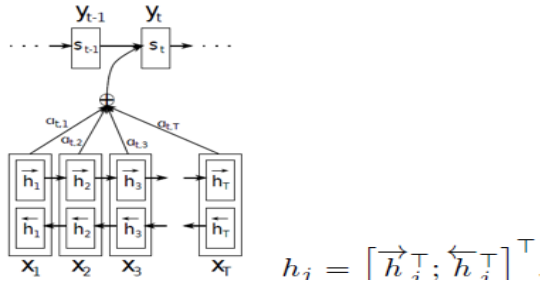

Figure-5: Attention based model

the weights will be learned by a feed-forward NN with its equation given below. The context-based vector c_i for the produced output word is y_i that is generated by the weighted summation of the annotations and the weights a_{ij} is calculated using a softmax function with the given equation:

$$a_{ij} = \frac{\exp(e_{ij})}{\sum_{k=1}^{T_x} \exp(e_{ik})}$$

$$e_{ij} = a(s_{i-1}, h_j) \quad c_i = \sum_{j=1}^{T_x} a_{ij} \cdot h_j$$

Here e_{ij} is the product of a neural feed forward of network that is represented by the functions to track the alignment from input in j as well as output in i.

H. Gated Recurrent Unit(GRU)

Gated Recurrent Units (GRUs) was developed by Kyunghyun Cho in 2014 as a gating function with Recurrent Neural Network(CNN)[32]. There is a lot of

similarity between a LSTM and GRU and GRU has limited parameters as compared with LSTM. Generally, GRU performs good enough than LSTM. GRU has use of gates for high performance namely two gates those are reset and update gate. Each reset gate defines how the new inputted data is merged with the prior information, while the update gate defined which prior memory will be maintained. GRUs has no background conditions (ct) like LSTMs. Update gate and reset gate makes forget gate and linked with past hidden layer. Therefore, in a GRU, the purpose of the LSTM reset gate is essentially separated into the reset and upgrades that shown in figure-6.

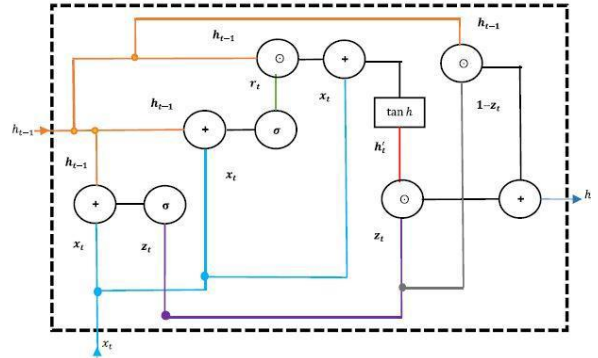

Figure-6:Gated Recurrent Unit [30]

Here x is used for input and r for reset gate and h for hidden state and z for update and sigma for

$$r_t = \sigma(W_{xr}x_t + W_{hr}h_{t-1} + br)$$

$$z_t = \sigma(W_{xz}x_t + W_{hz}h_{t-1} + b_z)$$

$$\hat{h}_t = \tanh(W_{xh}x_t + W_{hh}(r_t \odot h_{t-1}) + b_h)$$

$$h_t = z_t \odot h_{t-1} + (1-z_t) \odot \hat{h}_t$$

here W represents matrices, b represents model parameters, σ represents sigmoid function and the symbol \odot for the multiplication.

I. Capsule Network of Recurrent Neural Network(RNN)

The hierarchical relationship among local features, which can misclassify concepts due to their characteristics, could not be modeled in CNN. With max pooling in CNN, some important information would be lost, because the active neurons will just transfer to the next stage. Capsule networks have also been suggested to overcome these constraints. These networks tackle the spatial relations among entities by the use of dynamic routing with capsules. This is much better when compared to CNN's max pooling service. The dynamic routing is used to train the neuronal vectors of capsule networks; the dynamic routing is used to replace the conventional neural network cell node. The capsule networks allow it to be with relatively lower information than most of the other models of neural network. Main role of the capsule network to establish spatial relations and also the location directions focused on the conventional neural network, and by merging invariance with coverability to recognize objects. A first level capsule chooses to give its production towards

next level capsules which vectors provide a broad scalar element by lower level capsule projection. Figure 7 shows routing process in capsule network.

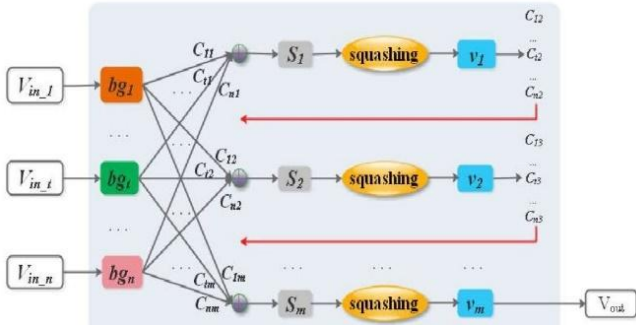

Figure-7: Routing process in Capsule network layer [33]

II. RELATED WORKS ON SENTIMENT ANALYSIS BASED ON DEEP LEARNING

Nowadays newer approaches using deep learning architecture performed with higher accuracy. Based on large-scale dataset, many deep learning approaches will systematically obtain the theoretically somaticized and syntactic features of texts that effectively tackle the shortage of artificial content engineering with improved intensity and precision. This section discusses and reviews the recent progress and development in deep learning-based sentiment analysis based on category with their analysis type, journals tasks, data, approach, sentiment analysis method, languages, advantages, and disadvantages. There are so much related works for sentiment analysis. Traditional methods are subdivided into following types: CNN, RNN. CNN have been used for sentence classification[28], in this method, the textual features can be extracted easily and relational research has made a lot of progress in sentiment analysis. Some CNN applications include use of character level for text classification [34] very deep CNN used for text classification [35], and Twitter abusive language detection by using CNN [36]. However, CNN is still not also fully satisfactory because it cannot capture long ranged feature and it does not recognize the important dependent features information of

its function and spatial position details. The above limitations of handling long ranged dependent feature of information have been almost solved by the Recurrent Neural Network (RNN) [32] [37] [38] and capsule neural network [8] [39]. RNN has been widely used in different fields for classification purposes with better result.

By studying the previous knowledge or features, RNN may predict results with long-range features. Because there are already certain flaws in the initial RNN, like gradient absence and gradient dispersion, authors have suggested a variety of RNN variants like LSTM: The LSTM is able to monitor long-term dependencies in sequences with storage units with gate structures which determine how data in storage can be used and modified in order to get more data to improve model calculation advantages.[32, 40], Dai introduces sequence learning in recurrent neural network for pretrained LSTMs model [41], Sayeed developed a deep neural networks with GRU and maximum pooling to classify the overlapping sentiments with high accuracy Bi-GRU [42]. Hinton developed the idea of the "capsule" at first with the vigorous creation of CNN and RNN[43]. Another works with capsule neural network with attention mechanism done by Du et al.[33].

From the analysis of this section and the table-3 below of related works it can be concluded that existing recent work in the field of sentiment analysis from text has good performance but still is very lacking in terms of coherence, context, semantic meaning handling, negation, modifiers, intensifier of the sentence. In recent deep learning-based method gives higher accuracy with handling independent textual features. There are also some limitations in deep learning such as handling of context and syntactic properly. Automatic emotion recognition remains an important research area to explore. However, most of the technique's has limitations. Damaged data cannot produce good result in measuring exact sentiments. So data should be secure when it need to be transferred from a source to another, a multi-level security of the sensitive text is ensured with encryption and compression algorithm[44].

Author and Year	Type	Journals	Task	Lexicon dataset or	Approach	Sentiment analysis features	Text	Performance	Advantages	Disadvantages
[16] - 2020	Hybrid	Neurocomputing, Elsevier	Opinion Mining	Works with five datasets: laptop2014, restaurant2014, restaurant2015, restaurant2016, and twitter	Glove Vector, Encoder, Cosine Similarity	Attention Mechanism done attention weights using mean value. Cosine similarity is used for position analysis for context and aspect	English	Accuracy, Macro-F1 percentage on data: Laptop2014(78.13,73.20) Restaurant2014 (84.38,71.31) Restaurant2015 (82.65,69.10) Restaurant2016(85.87,73.28) Twitter(76.56,72.19)	This method used Multi headed attention mechanism that increase the performance for sentiment classification	Its mean value-based tasks sometimes misses context, Uses cosine similarity that it cannot handle with the irrelevant portion of text
[13] - 2020	Hybrid	Neurocomputing	Opinion	Persian product	Uses SVM, and LR and	Uses author developed	Persian	Performance on Product review	Uses knowledge-based approach on	More dependent to DNN classifier, Works only

		ng, Elsevier	mining	corpora from www.digikala.com and hotel reviews from http://www.hellokish.com	DNN classifiers (LSTM-CNN)	dependency rules to extract sentiment feature using syntactic relation among the words		data: Precision:87% Recall:92% F1 Score:89% Accuracy:86.29%	the dependency rule for parsing purpose to extract opinion for this context is handled well than other approaches.	for Persian, depends on Google translator, unable to handle multi word expression, informal words, idioms, sarcasm, complex sentence.
[45] - 2019	Hybrid	IEEE, Access	Opinion Mining	Laptop review, Restaurant review and Twitter dataset	BERT with target dependency approach Glove Vector, Word2Vec	Uses Word Piece tokenizer, segment, and position embeddings and encoder layer for classification with BERT	English	Performance on Laptop data: Accuracy: 78.87 ±1.13, Micro F1:74.38 ±1.39 Restaurant data: Accuracy: 83.87 ±.27 ,MicroF1:79.61±0.79 Twitterdata:Accuracy:77.31 ±.79 ,MicroF1: 75.56±0.93	Did not consider the whole sentence, but focuses on target terms instead	Did not perform great with mixed sentiment polarities towards different aspects.
[46]- 2019	Deep learning	Computation and language, Computer Science, Cornell University Journal	Multilevel opinion Mining	TREC QA dataset	Capsule neural network	CNN and Capsule with routing with compressions, Adaptive KDE Routing	English	NLP-Capsule got performance of MAP 77.73% MRR 74.16%	Performs good with enough margin accuracy for multi-label text classification and question answering	Datasets need to be large and more realistic.
[33] - 2019	Hybrid	IEEE, Access	Opinion Mining	Movie Review data, NLPCC2014 dataset	BiGRU and CNN model and	CNN used for feature extraction BiGRU is used for and Capsule network can extract independent text features	English	82.55% accuracy for Movie review data 87.84% accuracy for NLPCC data	RNN Routing process of the Capsule network can extract independent text features i.e with word's position, semantic and syntactic structure.	This method performs well but attention-CNN layer is not rich enough with its operations for better performance
[47]- 2019	Semi-Supervised	IEEE, Access	Emotion Recognition	ISEAR and other 9 datasets	Deep learning	Uses CNN, Bi-LSTM, Word embeddings Word2Vec, GloVe, and FastText	English	Accuracy:74.6 % for ISEAR dataset, Good performance for other 9 datasets	Extract 6 basic emotions of Ekman's model, can handle semantic of sentence	Performance is limited with the data of word embedding
[7] - 2019	Supervised	Computation and Language, Cornell University Publisher	Emotion recognition	Semeval-2019 Task-3 data collections of labeled conversations	Deep learning: Bi-LSTM	Uses ASGD (Average Stochastic Gradient Descent) for training, uses attention based AWD-Bi-LSTM for classification.	English	Accuracy 75.82% for SemVal2019 data and also shown its different model data	Extract sad, happy, angry emotions in conversion	It has some lacking handling context and semantic relation among words in the sentence by this attention based BiLSTM
[8] - 2018	Hybrid	Conference paper ,ACL Anthology, ACL web	Emotion recognition	Kaggle toxicity detection dataset	Capsule Network with Dynamic Routing, LSTM	Word embedding, Focal Loss for better performance in Toxic comments classification	English	98.46 Accuracy on Kaggle data for toxic comment classification	It performs well for domain dependent dataset for Kaggle toxicity dataset	It is domain dependent but not suitable for other domain, cannot handle misspelled word.
[48]- 2018	Deep learning	Knowledge based system, Elsevier	Opinion classification	Amazon multi-domain sentiment dataset, Sanders	Attention mechanism	Uses two level modules named as domain module and sentiment	English	Accuracy Amazon Books 87.75% DVD 86.58% Electronics 87.50% Kitchen	Domain representation allow attention process for selecting the most	Domain dependent and do not perform for multi domain and multilingual text.

		r		Twitter Sentiment Dataset		module.		88.93% and for twitter dataset: Apple 86.76% Google 89.46% Microsoft 86.36% Twitter82.7%	domain based features.	
[28]-2014	Deep learning	Compu tation and langua ge., Cornell Univer sity Journal	Opinio n calssifi cation	MR,CR,TRE C,SST-1,SST-2	CNN	Multiplier channel of CNN for feature extraction, Regularization, Word Vector	English	It got 81.5% accuracy on Movie review dataset with non-static CNN and other 4 dataset performance is also good enough	This method comes with a breakthrough that performs better than all other previous methods	The limitation of this methods CNN is that it cannot handle dependent text feature sufficiently as LSTM or BiGRU.

Table 3: Deep learning based recent approach for sentiment analysis

DRAWBACKS OF DEEP LEARNING METHODS IN SENTIMENT ANALYSIS

From the review of deep learning in this article, it can be concluded that the deep learning architectures have shown outstanding results and important advances in sentiment analysis, there are still some disadvantage in using the following algorithms:

1. In order to ensure that a machine achieves the required output, most deep learning strategies allow several labelled data to be trained. Thus, for sentiment analysis research, a big set of dataset is necessary for training the deep learning architecture in order to predict the class labels correctly. Huge quantities of data can be exceedingly complicated and cumbersome to collect and label.
2. Unlike conventional machine learning or lexical approaches, which display what features are chosen to predict a certain feeling, it is difficult to find out what the real explanation for the neuronal network, by finding at weights in various stages, for predicting multilevel sentiment of text. It makes its challenging to achieve the result about the prediction analysis of the model of neural networks, as they function works looks like "black box."
3. Deep learning approaches such as CNN need to be tuned on initial parameters. You see this in Stoyanovsky et al[49]. The network's efficiency therefore relies on the value of the hyper parameters on the networks. This is also a difficult job to determine the optimum hyper parameter values.
4. The time it takes to train them is also really nice as there are a huge number of the parameters in deep learning. In addition, to increase performance[50], they need high performance based hardware such as GPUs and wide RAM.

III. CHALLENGES, LIMITATIONS AND FUTURE WORK IN SENTIMENT ANALYSIS WITH THE MODEL OF DEEP LEARNING

It is not possible for a machine to work like human to recognize sentiment. However, existing recent of sentiment analysis from text has generally performed with good accuracy. They are however still lacking in terms of lacking coherence, context, semantic meaning handling, negation, modifiers, and intensifier of the sentence. Context based task is giving some satisfaction for this problem. Lexicon or dictionary-based approaches can handle grammatical syntax but also have some limitations such as low accuracy, higher time complexity, dictionary, and domain dependency. Unsupervised based works give adaptability, simplicity, lower complexity but these methods also come with the limitations in time complexity and accuracy. But, Machine learning approaches like Tfidf, Naïve Bayes (NB) , Random Forest (RF),Support Vector (SVM), Logistic Regression (LR), Bayesian, k-means, Maximum entropy classification, Conditional Random Field (CRF) classifier work better for faster time but have limitation of handling semantics and dependency of words in the sentence. In recent deep learning-based approach CNN, LSTM, GRU, BERT, Capsule neural network gives higher accuracy by handling independent text features. There are also some limitations in deep learning such as handling of context and syntactic properly. Deep learning and quantum deep learning is the current trends in the area of sentiment analysis. Now live sentiment analysis is also the trends task for a game, product or other.

IV. CONCLUSION

This article gives a systematic review and analysis on deep learning methods of text sentiment analysis. It mainly introduces several different deep learning methods with textual data for different categories, and further summarizes and analyses their benefits, disadvantages, limitations and applicability etc. Sentiment analysis from test, image, speech, and video is very important in Human Computer Interaction. For social media, the text-based sentiment analysis plays a vital role. From this review paper we can conclude that deep learning method gives higher accuracy than all other methods. But in the case to

handle the coherence and semantic in sentence the knowledge-based approach is better but has the limitations of accuracy, time and space complexity. On the other hand, ontology-based sentiment analysis is good to handle text properly but it is time consuming as compared to all other approaches. Although machine learning based supervised technique is faster and more accurate but this type of method cannot handle negation, intensifier or modifier clause in the sentence. For this case the unsupervised knowledge-based approach and deep learning is good than all other methods.

REFERENCES

- [1] Kolkur, S., Dantal, G. and Mahe, R. 2015. Study of different levels for sentiment analysis. *International Journal of Current Engineering and Technology*. 5(2), 768-770.
- [2] Liu, B. 2012. Sentiment analysis and opinion mining. *Synthesis lectures on human language technologies*. 5(1), 1-167.
- [3] Hoogervorst, R., et al., 2016. Aspect-based sentiment analysis on the web using rhetorical structure theory. in *International Conference on Web Engineering*. Springer.
- [4] Bibi, M., et al., 2020. A Cooperative Binary-Clustering Framework Based on Majority Voting for Twitter Sentiment Analysis. *IEEE Access*.
- [5] Sailunaz, K. and Alhaji, R. 2019. Emotion and sentiment analysis from Twitter text. *Journal of Computational Science*. 36, 101003.
- [6] Seal, D., Roy, U.K. and Basak, R. 2020. Sentence-Level Emotion Detection from Text Based on Semantic Rules, in *Information and Communication Technology for Sustainable Development*. Springer. 423-430.
- [7] Ragheb, W., et al., 2019. Attention-based Modeling for Emotion Detection and Classification in Textual Conversations. *arXiv preprint arXiv:1906.07020*.
- [8] Srivastava, S., Khurana, P. and Tewari, V. 2018. Identifying aggression and toxicity in comments using capsule network. in *Proceedings of the First Workshop on Trolling, Aggression and Cyberbullying (TRAC-2018)*.
- [9] Alomari, E., Mehmood, R. and Katib, I. 2020. Sentiment Analysis of Arabic Tweets for Road Traffic Congestion and Event Detection, in *Smart Infrastructure and Applications*. Springer. 37-54.
- [10] Aloufi, S. and El Saddik, A. 2018. Sentiment identification in football-specific tweets. *IEEE Access*. 6, 78609-78621.
- [11] Ruz, G.A., Henríquez, P.A. and Mascareño, A. 2020, Sentiment analysis of Twitter data during critical events through Bayesian networks classifiers. *Future Generation Computer Systems*. 106, 92-104.
- [12] Wu, D. and Cui, Y. 2018. Disaster early warning and damage assessment analysis using social media data and geo-location information. *Decision Support Systems*. 111, 48-59.
- [13] Dashtipour, K., et al., 2020. A hybrid Persian sentiment analysis framework: Integrating dependency grammar based rules and deep neural networks. *Neurocomputing*. 380, 1-10.
- [14] Kausar, S., et al., 2019. A Sentiment Polarity Categorization Technique for Online Product Reviews. *IEEE Access*.
- [15] Trinh, S., et al., 2016. Lexicon-based sentiment analysis of Facebook comments in Vietnamese language, in *Recent developments in intelligent information and database systems*. Springer. 263-276.
- [16] Xu, Q., et al., 2020. Aspect-based sentiment classification with multi-attention network. *Neurocomputing*. 388, 135-143.
- [17] Ren, R., Wu, D.D. and Liu, T. 2018. Forecasting stock market movement direction using sentiment analysis and support vector machine. *IEEE Systems Journal*. 13(1), 760-770.
- [18] Kušen, E. and Strembeck, M. 2018. Politics, sentiments, and misinformation: An analysis of the Twitter discussion on the 2016 Austrian Presidential Elections. *Online Social Networks and Media*. 5, 37-50.
- [19] Haselmayer, M. and Jenny, M. 2017. Sentiment analysis of political communication: combining a dictionary approach with crowdcoding. *Quality & quantity*. 51(6), 2623-2646.
- [20] Mikolov, T., et al., 2013. Efficient estimation of word representations in vector space. *arXiv preprint arXiv:1301.3781*.
- [21] Zhai, S. and Zhang, Z.M. 2016. Semisupervised autoencoder for sentiment analysis. in *Thirtieth AAAI Conference on Artificial Intelligence*.
- [22] Zhang, Y., Jin, R. and Zhou, Z.-H. 2010. Understanding bag-of-words model: a statistical framework. *International Journal of Machine Learning and Cybernetics*. 1(1-4), 43-52.
- [23] Zhang, M., Zhang, Y. and Vo, D.-T. 2016. Gated neural networks for targeted sentiment analysis. in *Thirtieth AAAI Conference on Artificial Intelligence*.
- [24] Ma, Y., Peng, H. and Cambria, E. 2018. Targeted aspect-based sentiment analysis via embedding commonsense knowledge into an attentive LSTM. in *Thirty-second AAAI conference on artificial intelligence*.
- [25] Xu, H., et al., 2018. Double embeddings and cnn-based sequence labeling for aspect extraction. *arXiv preprint arXiv:1805.04601*.
- [26] Pennington, J., Socher, R. and Manning, C.D. 2014. Glove: Global vectors for word representation. in *Proceedings of the 2014 conference on empirical methods in natural language processing (EMNLP)*.
- [27] Devlin, J., et al., 2018. Bert: Pre-training of deep bidirectional transformers for language understanding. *arXiv preprint arXiv:1810.04805*.
- [28] Kim, Y. 2014. Convolutional neural networks for sentence classification. *arXiv preprint arXiv:1408.5882*.
- [29] Bahdanau, D., Cho, K. and Bengio, Y. 2014. Neural machine translation by jointly learning to align and translate. *arXiv preprint arXiv:1409.0473*.
- [30] Cho, K., et al., 2014. Learning phrase representations using RNN encoder-decoder for statistical machine translation. *arXiv preprint arXiv:1406.1078*.
- [31] Zhang, X., Zhao, J. and LeCun, Y. 2015. Character-level convolutional networks for text classification. in *Advances in neural information processing systems*.
- [32] Conneau, A., et al., 2016. Very deep convolutional networks for text classification. *arXiv preprint arXiv:1606.01781*.

- [33] Park, J.H. and Fung, P. 2017. One-step and two-step classification for abusive language detection on twitter. arXiv preprint arXiv:1706.01206.
- [34] Lai, S., et al., 2015.Recurrent convolutional neural networks for text classification. in Twenty-ninth AAAI conference on artificial intelligence.
- [35] Wang, X., Jiang, W. and Luo, Z. 2016.Combination of convolutional and recurrent neural network for sentiment analysis of short texts. in Proceedings of COLING 2016, the 26th international conference on computational linguistics: Technical papers.
- [36] Dong, Y., et al., 2020. A Sentiment Analysis Method of Capsule Network Based on BiLSTM. IEEE Access, 8, 37014-37020.
- [37] Mousa, A. and Schuller, B. 2017.Contextual bidirectional long short-term memory recurrent neural network language models: A generative approach to sentiment analysis. in Proceedings of the 15th Conference of the European Chapter of the Association for Computational Linguistics.1, Long Papers.
- [38] Dai, A.M. and Le, Q.V. 2015.Semi-supervised sequence learning. in Advances in neural information processing systems.
- [39] Saeed, H.H., Shahzad, K. and Kamiran, F. 2018. Overlapping toxic sentiment classification using deep neural architectures. in 2018 IEEE International Conference on Data Mining Workshops (ICDMW). IEEE.
- [40] Hinton, G.E., Krizhevsky, A. and Wang, S.D. 2011. Transforming auto-encoders. in International conference on artificial neural networks. Springer.
- [41] Du, Y., et al., 2019. A novel capsule based hybrid neural network for sentiment classification. IEEE Access. 7, 39321-39328.
- [42] Alsaidi, A., et al., 2018. Compression multi-level crypto stego security of texts utilizing colored email forwarding. Journal of Computer Science & Computational Mathematics (JCSCM). 8(3), 33-42.
- [43] Gao, Z., et al., 2019. Target-Dependent Sentiment Classification With BERT. IEEE Access, 7, 154290-154299.
- [44] Zhao, W., et al., 2019. Towards scalable and reliable capsule networks for challenging NLP applications. arXiv preprint arXiv:1906.02829.
- [45] Batbaatar, E., Li, M. and Ryu, K.H. 2019.Semantic-Emotion Neural Network for Emotion Recognition From Text. IEEE Access. 7, 111866-111878.
- [46] Yuan, Z., et al., 2018. Domain attention model for multi-domain sentiment classification. Knowledge-Based Systems. 155, 1-10.
- [47] Stojanovski, D., et al., 2015.Twitter sentiment analysis using deep convolutional neural network. in International Conference on Hybrid Artificial Intelligence Systems. Springer.
- [48] Dufourq, E. and Bassett, B.A. 2017.Eden: Evolutionary deep networks for efficient machine learning. in 2017 Pattern Recognition Association of South Africa and Robotics and Mechatronics (PRASA-RobMech). IEEE.